

Forzadores Rotor Externo para Refrigeración

TOTALINE



YWF Axial Fans

**Forzadores Axiales con Motores de Rotor Externo
Series YWF
Para aplicaciones en Evaporadores y Un. Condensadoras.
Con Certificación Eléctrica.**

TOTALINE



Totaline Centro
(011) 4384 5509

Totaline Norte
(011) 4721 0000

Totaline Sur
(011) 4240 1700

Totaline Oeste
(011) 4459 3004

Totaline Rosario
(0341) 437 5606

(011) 4837 5052

Ventas a Interior
(011) 4837 5028

(011) 4837 5104

www.totaline.com.ar

Repuestos y personas. Trabajando Juntos

Forzadores Rotor Externo para Refrigeración



WEIGUANG es un fabricante chino de motores, es una empresa de alta tecnología, que posee certificado de calidad ISO9001:2000, ISO14001 de implementación de gestión medio ambiental e ISO18001 de sistemas de gestión de la seguridad y la salud ocupacional. Sus productos tienen aprobaciones de:



- Los forzadores de la serie YWF poseen motores de rotor externo. Estos motores tienen como características: Estructura compacta, fácil instalación, conservación de energía y alta eficiencia.
- Los motores de la serie YWF son del tipo asíncrono, los monofásicos con capacitor de marcha.
- La aislación de los motores es de la clase B o F.
- El voltaje de los monofásicos es 220V/50Hz y el de los trifásicos es 380V/50Hz.
- Son ampliamente utilizados en aplicaciones de evaporadores, condensadores y otras aplicaciones de refrigeración y ventilación.
- El rango de temperatura ambiente para aplicación de los forzadores en condensadores es de -30°C a + 60°C.
- La vida útil promedio de los motores es de 30.000 horas.
- Antes de conectar el motor verifique la tensión del mismo con la red y conecte el mismo a tierra.
- Los forzadores YWF tienen certificación de Seguridad Eléctrica en el país:



DIAGRAMA DE CABLEADO

MONOFASICO

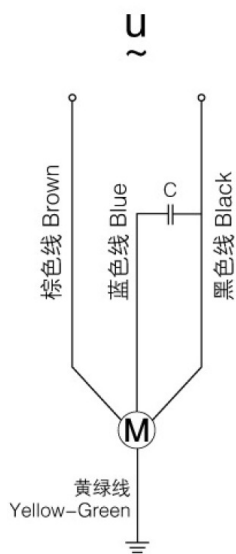

TRIFASICO

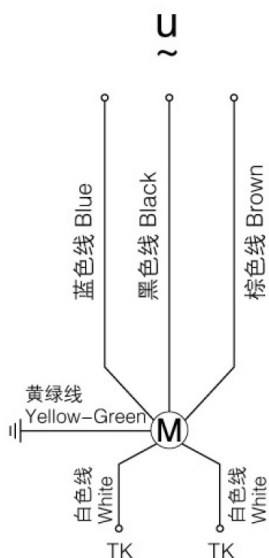

SIGNIFICADO DE CÓDIGO

YWF - 4 E - 350 - S - 102 / 34 - *

① ②③ ④ ⑤ ⑥ ⑦ ⑧

- ① 交流感应异步外转子风扇电动机
AC Induction asynchronous external rotor fan motor
- ② 电机极数
Motor poles
- ③ E - 单相电容运转, D - 三相异步运转
E - Single phase capacitor operation, D - Three phases asynchronous operation
- ④ 风叶直径
The diameter of the fan blade
- ⑤ 风向: S-吸风, B-吹风
Air direction: S-Sucking, B-Blowing
- ⑥ 转子直径
The diameter of the rotor
- ⑦ 铁芯叠厚
The thickness of laminated core
- ⑧ 风机特征:
G-网罩, B-方框, T-圆筒, R-圆框, E-IP54, J-冷风机专用
Characteristics of the fan motor:
G-Grid, B-Square Frame, T-Cylinder, R-Round Frame, E-Insulation class IP54, J-Special for air cooler



Repuestos y personas. Trabajando Juntos

Forzadores Rotor Externo para Refrigeración

YWF Axial Fans

Código	FAS.	VOLT.	FREQ.	POL.	CAP.	CON.	W	AMP.	DIAM.	RPM	SENT.A.	C.M3/H	DbA	Kg
WG-YWF4E-250	1	220V	50Hz	4	2MF		60	0.23	250mm	1400	ASP.	730	55	3
WG-YWF4E-300	1	220V	50Hz	4	3MF		75	0.35	300mm	1380	ASP.	1620	58	3.3
WG-YWF4E-350	1	220V	50Hz	4	4MF		140	0.65	350mm	1380	ASP.	2270	62	4.9
WG-YWF4D-350	3	380V	50Hz	4	NA		150	0.38	350mm	1380	ASP.	2290	62	4.9
WG-YWF4E-400	1	220V	50Hz	4	6MF		180	0.82	400mm	1380	ASP.	3400	68	7.2
WG-YWF4D-400	3	380V	50Hz	4	NA		180	0.47	400mm	1380	ASP.	3400	68	7.2
WG-YWF4E-450	1	220V	50Hz	4	8MF		250	1.20	450mm	1350	ASP.	4620	68	7.2
WG-YWF4D-450	3	380V	50Hz	4	NA		250	0.60	450mm	1360	ASP.	4800	68	7.2
WG-YWF4E-500	1	220V	50Hz	4	10MF		420	1.95	500mm	1300	ASP.	6420	72	9.5
WG-YWF4D-500	3	380V	50Hz	4	NA		450	0.90	500mm	1300	ASP.	6570	72	9.5
WG-YWF4D-630	3	380V	50Hz	4	NA		880	1.60	630mm	1320	ASP.	11600	78	15
WG-YWF6D-710	3	380V	50Hz	6	NA	TRIAN.	900	1.75	710mm	900	ASP.	15670	80	25
						ESTR.	650	1.20		730		12750		



WG-YWF4E-250



WG-YWF4E-300



WG-YWF4E-350
WG-YWF4D-350



WG-YWF4E-400
WG-YWF4D-400



WG-YWF4E-450
WG-YWF4D-450



WG-YWF4E-500
WG-YWF4D-500



WG-YWF4D-630



WG-YWF6D-710

TOTALINE

WEIGUANG
微光电机

Repuestos y personas. Trabajando Juntos

Forzadores Rotor Externo para Refrigeración

WG-YWF4E-250

FORZ.AXIAL ROT.EXT.C/REJ.250MM 220V ASP.

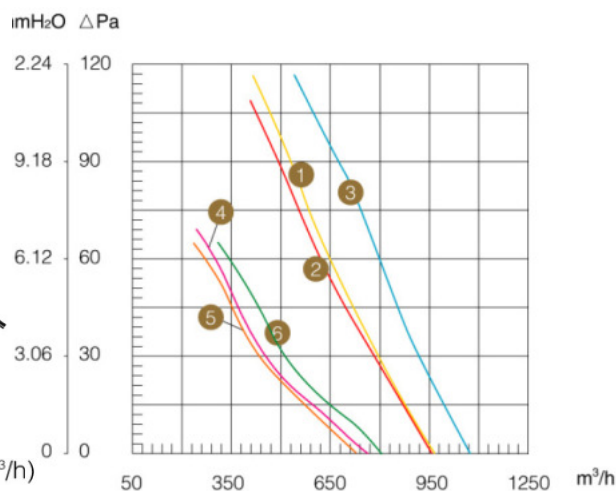
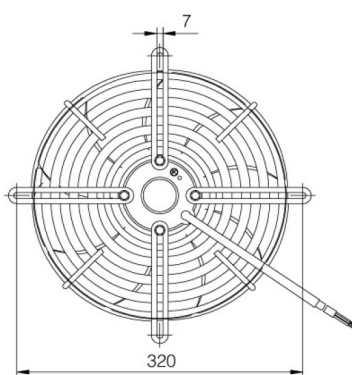
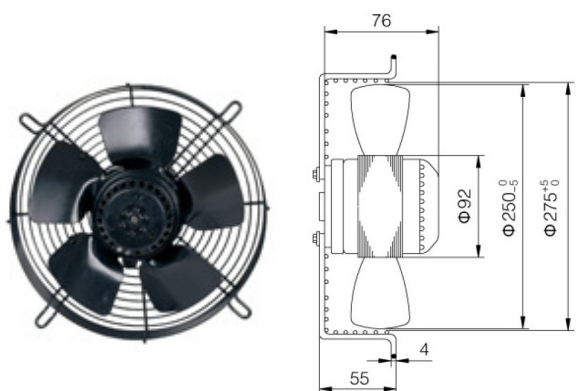

5 4E-250 220V/50Hz 0~60Pa (20Pa-520m³/h)

WG-YWF4E-300

FORZ.AXIAL ROT.EXT.C/REJ.300MM 220V ASP.

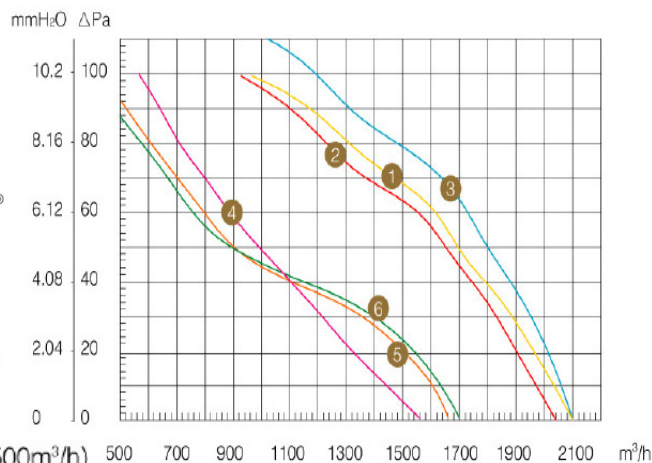
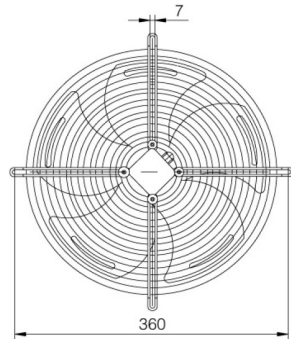
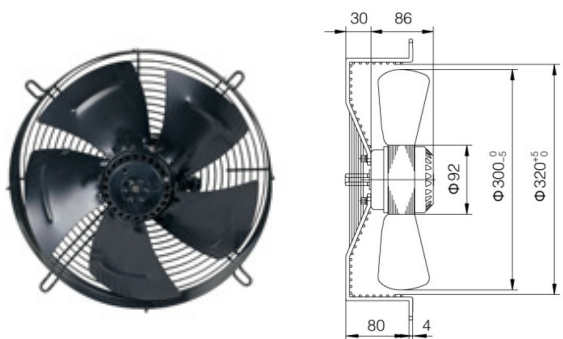

5 4E-300 220V/50Hz 0~60Pa (20Pa-1500m³/h)

WG-YWF4E-350

FORZ.AXIAL ROT.EXT.C/REJ.350MM 220V ASP.

WG-YWF4D-350

FORZ.AXIAL ROT.EXT.C/REJ.350MM 380V ASP.

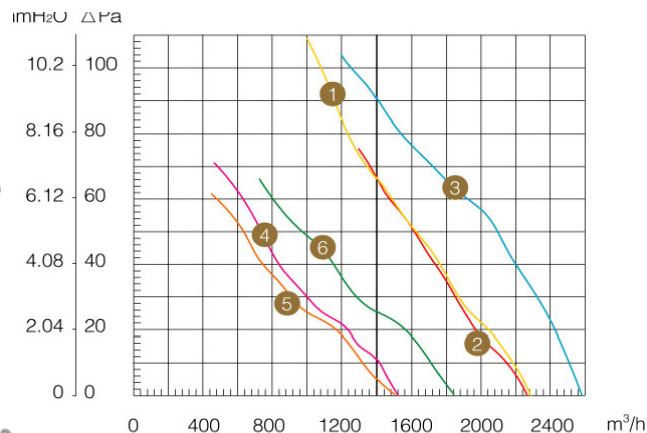
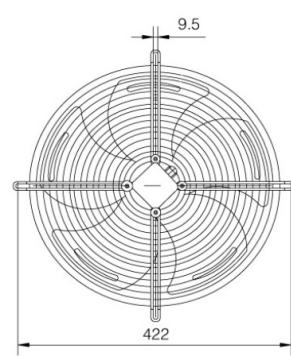
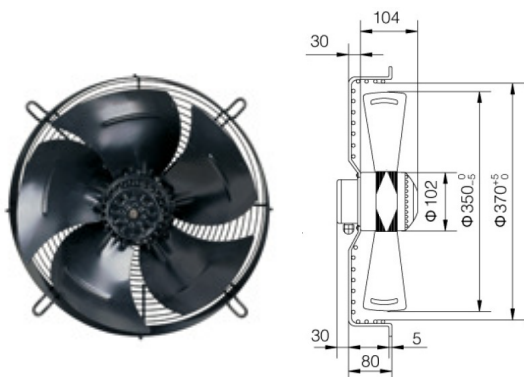

1 4D-350 380V/50Hz 0~90Pa (20Pa-2090m³/h)
2 4E-350 220V/50Hz 0~90Pa (20Pa-1960m³/h)



Repuestos y personas. Trabajando Juntos

Forzadores Rotor Externo para Refrigeración

WG-YWF4E-400

FORZ.AXIAL ROT.EXT.C/REJ.400MM 220V ASP.

WG-YWF4D-400

FORZ.AXIAL ROT.EXT.C/REJ.400MM 380V ASP.

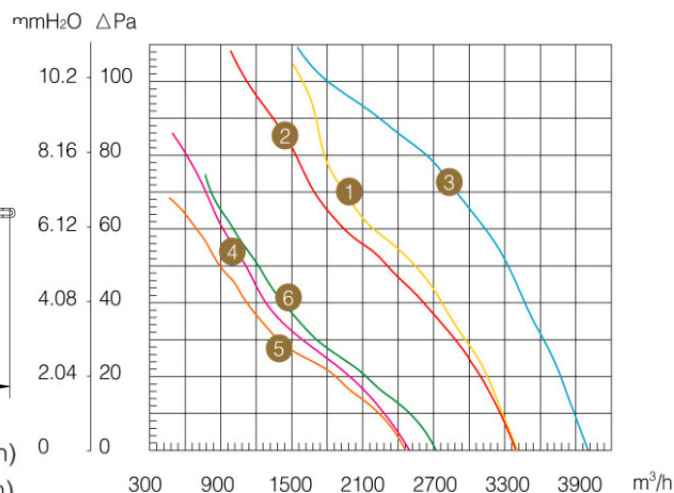
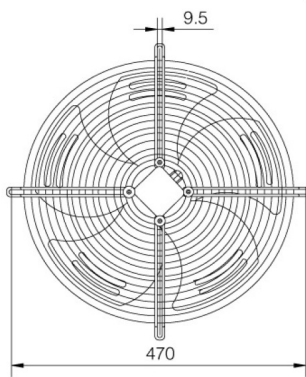
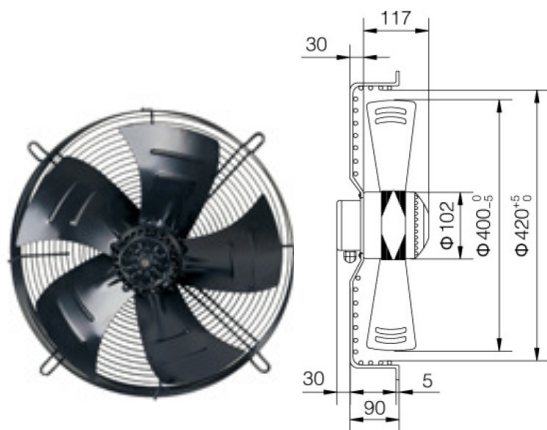

- 1 4D-400 380V/50Hz 0~90Pa (20Pa-3150m³/h)
- 2 4E-400 220V/50Hz 0~90Pa (20Pa-3200m³/h)

WG-YWF4E-450

FORZ.AXIAL ROT.EXT.C/REJ.450MM 220V ASP.

WG-YWF4D-450

FORZ.AXIAL ROT.EXT.C/REJ.450MM 380V ASP.

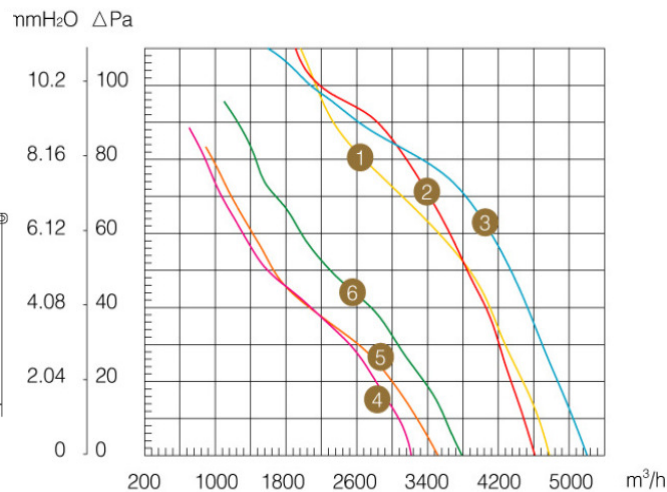
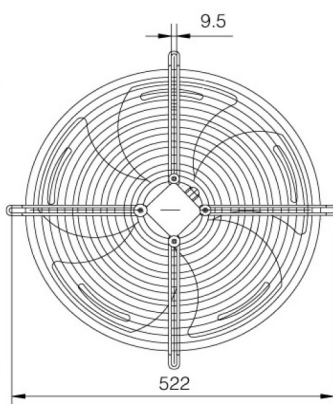
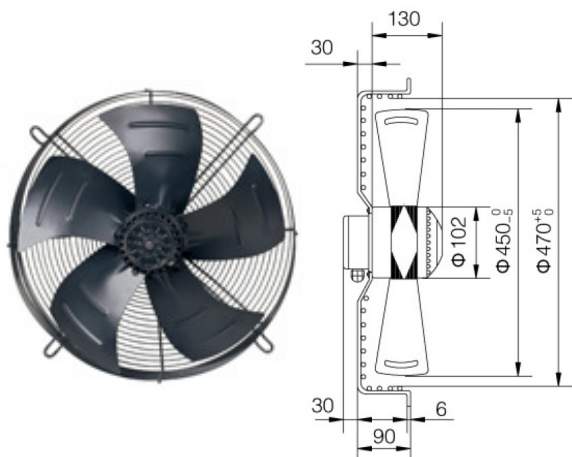

- 1 4D-450 380V/50Hz 0~90Pa (20Pa-4450m³/h)
- 2 4E-450 220V/50Hz 0~90Pa (20Pa-4210m³/h)



Repuestos y personas. Trabajando Juntos

Forzadores Rotor Externo para Refrigeración

WG-YWF4E-500

FORZ.AXIAL ROT.EXT.C/REJ.500MM 220V ASP.

WG-YWF4D-500

FORZ.AXIAL ROT.EXT.C/REJ.500MM 380V ASP.

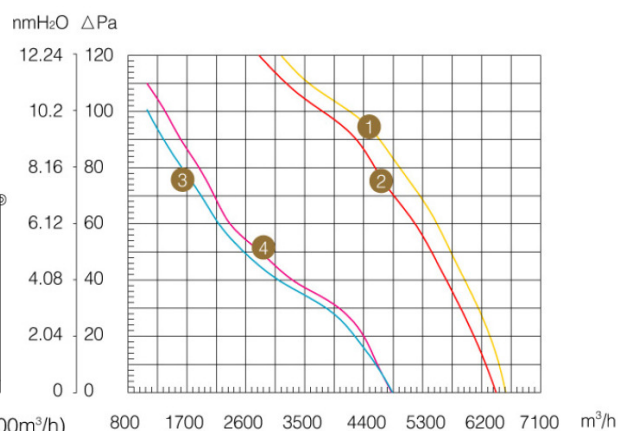
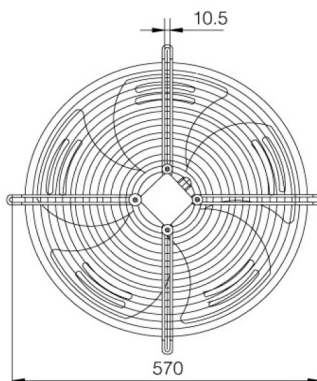
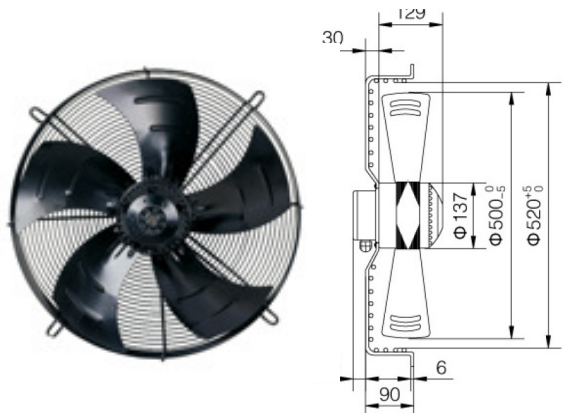

1 4D-500 380V/50Hz 0~90Pa (20Pa-6300m³/h)

2 4E-500 220V/50Hz 0~90Pa (20Pa-6000m³/h)

WG-YWF4D-630

FORZ.AXIAL ROT.EXT.C/REJ.630MM 380V ASP.

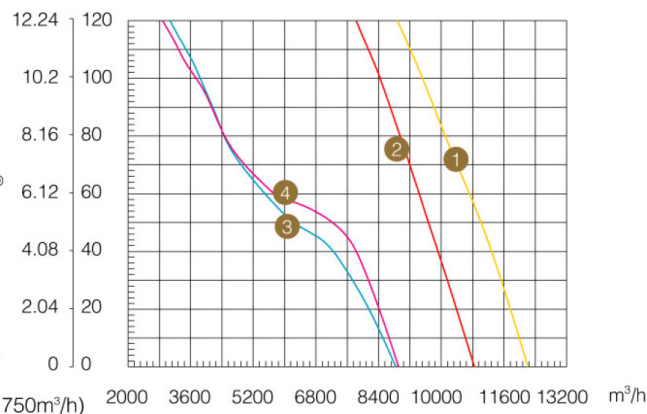
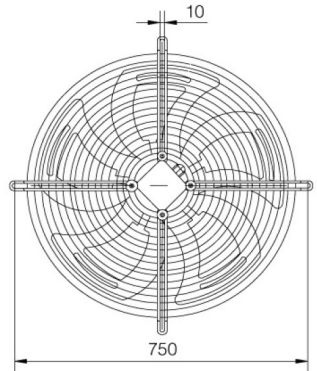
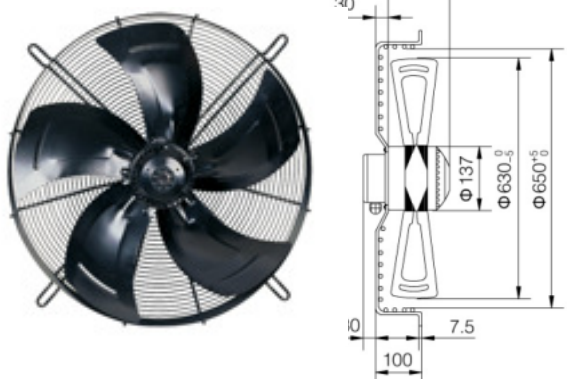

1 4D-630 380V/50Hz 0~120Pa (20Pa-11750m³/h)

WG-YWF6D-710

FORZ.AXIAL ROT.EXT.C/REJ.710MM 380V ASP.

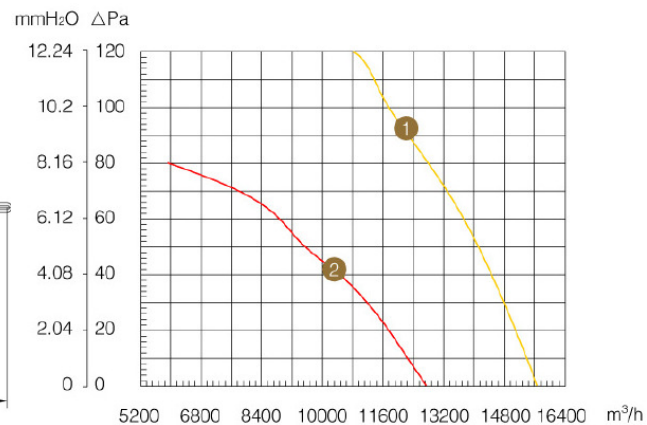
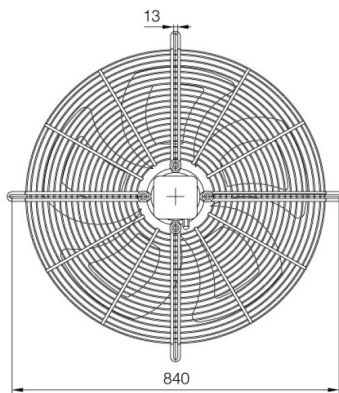
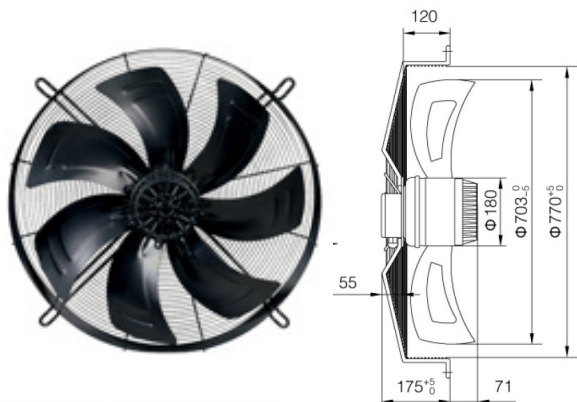

1 6D-710 Δ380V/50Hz 0~120Pa (20Pa-15060m³/h)

2 6D-710 Y220V/50Hz 0~120Pa (20Pa-11680m³/h)



Repuestos y personas. Trabajando Juntos